

DRC2



DRC4



DRC6

Model	Load Capacity (Kg/pc)	Bolt Size (mm)	d (mm)	Dia (D) (mm)	H (mm)	Adjustment (mm)	Bottom pad Type	Bottom pad Thickness (mm)	Coeff. of Friction against Concrete	Natural Frequency at Max. Load (Hz)	Temperature Range (°C)
DRC1-u-150-FG-GR	350	M12X100	98	109	150	8	Du	15	0.9	18	From -16 to 90
DRC2-u-150-FG-GR	600	M16X100	125	150	150	8	Du	15	0.9	18	From -16 to 90
DRC3-u-150-FG-GR	900	M16X100	150	170	150	10	Du	15	0.9	18	From -16 to 90
DRC4-u-150-FG-GR	1400	M18X150	180	210	150	10	Du	15	0.9	18	From -16 to 90
DRC5-u-150-FG-GR	1900	M20X150	204	240	150	12	Du	15	0.9	18	From -16 to 90
DRC6-u-150-FG-GR	2500	M20X150	235	270	150	12	Du	15	0.9	18	From -16 to 90

Applications: Tool Room Machines, Plastic Injection Moulding Machines, Pressure Die Casting Machines, Shaper, Printing and Textile Machines etc.

DRC1-u-10-145-FG-GR	350	M12X100	98	109	145	8	Du-10	10	0.9	18	From -16 to 90
DRC2-u-10-145-FG-GR	600	M16X100	125	150	145	8	Du-10	10	0.9	18	From -16 to 90
DRC3-u-10-145-FG-GR	900	M16X100	150	170	145	10	Du-10	10	0.9	18	From -16 to 90
DRC4-u-10-145-FG-GR	1400	M18X150	180	210	145	10	Du-10	10	0.9	18	From -16 to 90
DRC5-u-10-145-FG-GR	1900	M20X150	204	240	145	12	Du-10	10	0.9	18	From -16 to 90
DRC6-u-10-145-FG-GR	2500	M20X150	235	270	145	12	Du-10	10	0.9	18	From -16 to 90

Applications: Tool Room Machines, Plastic Injection Moulding Machines, Pressure Die Casting Machines, Shaper, Printing and Textile Machines etc.

DRC1-u-12-147-FG-GR	350	M12X100	98	109	147	8	Du-12	12	0.9	18	From -16 to 90
DRC2-u-12-147-FG-GR	600	M16X100	125	150	147	8	Du-12	12	0.9	18	From -16 to 90
DRC3-u-12-147-FG-GR	900	M16X100	150	170	147	10	Du-12	12	0.9	18	From -16 to 90
DRC4-u-12-147-FG-GR	1400	M18X150	180	210	147	10	Du-12	12	0.9	18	From -16 to 90
DRC5-u-12-147-FG-GR	1900	M20X150	204	240	147	12	Du-12	12	0.9	18	From -16 to 90
DRC6-u-12-147-FG-GR	2500	M20X150	235	270	147	12	Du-12	12	0.9	18	From -16 to 90

Applications: Tool Room Machines, Plastic Injection Moulding Machines, Pressure Die Casting Machines, Shaper, Printing and Textile Machines etc.

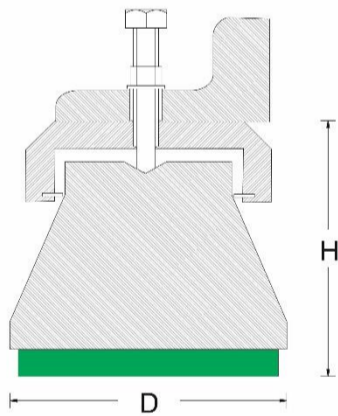

DRC2



DRC4



DRC6

DRC1-m-150-FG-GR	450	M12X100	98	109	150	8	Dm	15	0.7	30	From -16 to 90
DRC2-m-150-FG-GR	800	M16X100	125	150	150	8	Dm	15	0.7	30	From -16 to 90
DRC3-m-150-FG-GR	1150	M16X100	150	170	150	10	Dm	15	0.7	30	From -16 to 90
DRC4-m-150-FG-GR	1750	M18X150	180	210	150	10	Dm	15	0.7	30	From -16 to 90
DRC5-m-150-FG-GR	2400	M20X150	204	240	150	12	Dm	15	0.7	30	From -16 to 90
DRC6-m-150-FG-GR	3200	M20X150	235	270	150	12	Dm	15	0.7	30	From -16 to 90

Applications: Power Presses, Stamping Machines, Shearing Machines, Punching Machines. For machines with high vertical impact.

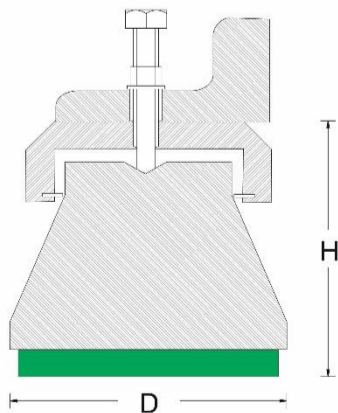

DRC2



DRC4



DRC6

DRC1-i-160-FG-GR	890	M12X100	98	109	160	8	Di	25	0.8	7	From -16 to 90
DRC2-i-160-FG-GR	1720	M16X100	125	150	160	8	Di	25	0.8	7	From -16 to 90
DRC3-i-160-FG-GR	2470	M16X100	150	170	160	10	Di	25	0.8	7	From -16 to 90

DRC4-i-160-FG-GR	3180	M18X150	180	210	160	10	Di	25	0.8	7	From -16 to 90
DRC5-i-160-FG-GR	5320	M20X150	204	240	160	12	Di	25	0.8	7	From -16 to 90
DRC6-i-160-FG-GR	6870	M20X150	235	270	160	12	Di	25	0.8	7	From -16 to 90

Applications: Power Presses, Stamping Machines, Shearing Machines, Punching Machines. For machines with high vertical impact.

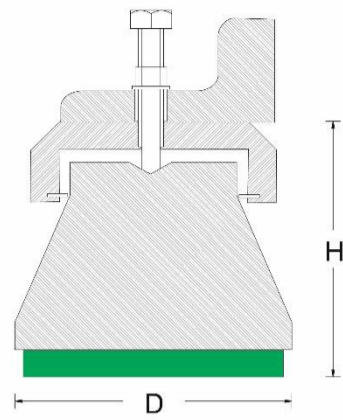

DRC2



DRC4



DRC6

DRC1-p1-150-FG-GR	250	M12X100	98	109	150	8	Dp1	15	0.8	7	From -16 to 90
DRC2-p1-150-FG-GR	490	M16X100	125	150	150	8	Dp1	15	0.8	7	From -16 to 90
DRC3-p1-150-FG-GR	700	M16X100	150	170	150	10	Dp1	15	0.8	7	From -16 to 90
DRC4-p1-150-FG-GR	900	M18X150	180	210	150	10	Dp1	15	0.8	7	From -16 to 90
DRC5-p1-150-FG-GR	1520	M20X150	204	240	150	12	Dp1	15	0.8	7	From -16 to 90
DRC6-p1-150-FG-GR	1960	M20X150	235	270	150	12	Dp1	15	0.8	7	From -16 to 90

Applications: Power Presses, Stamping Machines, Shearing Machines, Punching Machines. For machines with high vertical impact.

DRC1-p2-155-FG-GR	320	M12X100	98	109	155	8	Dp2	20	0.8	12	From -16 to 90
DRC2-p2-155-FG-GR	610	M16X100	125	150	155	8	Dp2	20	0.8	12	From -16 to 90
DRC3-p2-155-FG-GR	880	M16X100	150	170	155	10	Dp2	20	0.8	12	From -16 to 90
DRC4-p2-155-FG-GR	1130	M18X150	180	210	155	10	Dp2	20	0.8	12	From -16 to 90
DRC5-p2-155-FG-GR	1900	M20X150	204	240	155	12	Dp2	20	0.8	12	From -16 to 90
DRC6-p2-155-FG-GR	2450	M20X150	235	270	155	12	Dp2	20	0.8	12	From -16 to 90

Applications: Medium Presses, Punching Presses, Centreless Grinding Machines, Gear Shapers, High Speed Machines on upper floors.

DRC1-p3-159-FG-GR	380	M12X100	98	109	159	8	Dp3	24	0.8	7	From -16 to 90
DRC2-p3-159-FG-GR	730	M16X100	125	150	159	8	Dp3	24	0.8	7	From -16 to 90
DRC3-p3-159-FG-GR	1060	M16X100	150	170	159	10	Dp3	24	0.8	7	From -16 to 90
DRC4-p3-159-FG-GR	1360	M18X150	180	210	159	10	Dp3	24	0.8	7	From -16 to 90
DRC5-p3-159-FG-GR	2280	M20X150	204	240	159	12	Dp3	24	0.8	7	From -16 to 90
DRC6-p3-159-FG-GR	2940	M20X150	235	270	159	12	Dp3	24	0.8	7	From -16 to 90

Applications: Tool Room Machines on suspended Floors, Light Weight Presses, Compressors etc.

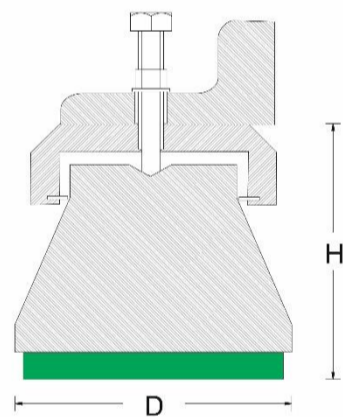

DRC2



DRC4



DRC6

DRC1-s1-155-FG-GR	200	M12X100	98	109	155	8	Ds1	20	0.8	15	From -16 to 90
DRC2-s1-155-FG-GR	375	M16X100	125	150	155	8	Ds1	20	0.8	15	From -16 to 90
DRC3-s1-155-FG-GR	575	M16X100	150	170	155	10	Ds1	20	0.8	15	From -16 to 90
DRC4-s1-155-FG-GR	800	M18X150	180	210	155	10	Ds1	20	0.8	15	From -16 to 90
DRC5-s1-155-FG-GR	1100	M20X150	204	240	155	12	Ds1	20	0.8	15	From -16 to 90
DRC6-s1-155-FG-GR	1500	M20X150	235	270	155	12	Ds1	20	0.8	15	From -16 to 90

Applications: Tool Room Machines, Plastic Injection Moulding Machines, Pressure Die Casting Machines, Shaper, Printing and Textile Machines etc.

DRC1-s2-160-FG-GR	300	M12X100	98	109	160	8	Ds2	25	0.8	8	From -16 to 90
DRC2-s2-160-FG-GR	550	M16X100	125	150	160	8	Ds2	25	0.8	8	From -16 to 90
DRC3-s2-160-FG-GR	850	M16X100	150	170	160	10	Ds2	25	0.8	8	From -16 to 90
DRC4-s2-160-FG-GR	1250	M18X150	180	210	160	10	Ds2	25	0.8	8	From -16 to 90
DRC5-s2-160-FG-GR	1700	M20X150	204	240	160	12	Ds2	25	0.8	8	From -16 to 90
DRC6-s2-160-FG-GR	2200	M20X150	235	270	160	12	Ds2	25	0.8	8	From -16 to 90

Applications: Power Presses, Stamping Machines, Shearing Machines, Punching Machines. For machines with high vertical impact.

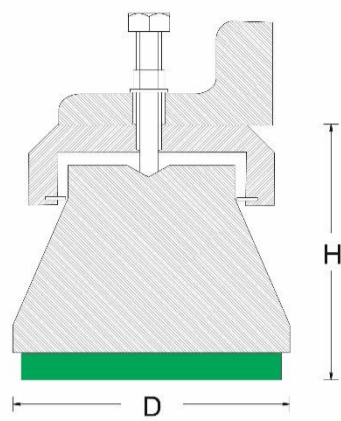

DRC2



DRC4



DRC6

DRC1-hs1-200-FG-GR	1270	M12X100	98	109	200	8	Dhs1	65	0.8	6	From -16 to 90
DRC2-hs1-200-FG-GR	2450	M16X100	125	150	200	8	Dhs1	65	0.8	6	From -16 to 90
DRC3-hs1-200-FG-GR	3530	M16X100	150	170	200	10	Dhs1	65	0.8	6	From -16 to 90
DRC4-hs1-200-FG-GR	4540	M18X150	180	210	200	10	Dhs1	65	0.8	6	From -16 to 90
DRC5-hs1-200-FG-GR	7600	M20X150	204	240	200	12	Dhs1	65	0.8	6	From -16 to 90
DRC6-hs1-200-FG-GR	9820	M20X150	235	270	200	12	Dhs1	65	0.8	6	From -16 to 90

Applications : Forging Hammers, Heavy Gen Sets, Heavy Industrial machines, Test Rigs, Heavy presses etc.

DRC1-hs2-200-FG-GR	510	M12X100	98	109	200	8	Dhs2	65	0.8	4	From -16 to 90
DRC2-hs2-200-FG-GR	900	M16X100	125	150	200	8	Dhs2	65	0.8	4	From -16 to 90
DRC3-hs2-200-FG-GR	1410	M16X100	150	170	200	10	Dhs2	65	0.8	4	From -16 to 90
DRC4-hs2-200-FG-GR	1810	M18X150	180	210	200	10	Dhs2	65	0.8	4	From -16 to 90
DRC5-hs2-200-FG-GR	3040	M20X150	204	240	200	12	Dhs2	65	0.8	4	From -16 to 90
DRC6-hs2-200-FG-GR	3930	M20X150	235	270	200	12	Dhs2	65	0.8	4	From -16 to 90

Applications : Forging Hammers, Heavy Gen Sets, Heavy Industrial machines, Test Rigs, Heavy presses, crushers etc.

DRC1-hs3-185-FG-GR	1780	M12X100	98	109	185	8	Dhs3	50	0.8	7	From -16 to 90
DRC2-hs3-185-FG-GR	3440	M16X100	125	150	185	8	Dhs3	50	0.8	7	From -16 to 90
DRC3-hs3-185-FG-GR	4950	M16X100	150	170	185	10	Dhs3	50	0.8	7	From -16 to 90
DRC4-hs3-185-FG-GR	6350	M18X150	180	210	185	10	Dhs3	50	0.8	7	From -16 to 90
DRC5-hs3-185-FG-GR	10640	M20X150	204	240	185	12	Dhs3	50	0.8	7	From -16 to 90
DRC6-hs3-185-FG-GR	13740	M20X150	235	270	185	12	Dhs3	50	0.8	7	From -16 to 90

Applications : Forging Hammers, Heavy Gen Sets, Heavy Industrial machines, Test Rigs, Heavy presses etc.

DRC1-hs4-185-FG-GR	760	M12X100	98	109	185	8	Dhs4	50	0.8	5	From -16 to 90
DRC2-hs4-185-FG-GR	1470	M16X100	125	150	185	8	Dhs4	50	0.8	5	From -16 to 90
DRC3-hs4-185-FG-GR	2120	M16X100	150	170	185	10	Dhs4	50	0.8	5	From -16 to 90
DRC4-hs4-185-FG-GR	2720	M18X150	180	210	185	10	Dhs4	50	0.8	5	From -16 to 90
DRC5-hs4-185-FG-GR	4960	M20X150	204	240	185	12	Dhs4	50	0.8	5	From -16 to 90
DRC6-hs4-185-FG-GR	5890	M20X150	235	270	185	12	Dhs4	50	0.8	5	From -16 to 90

Applications : Forging Hammers, Heavy Gen Sets, Heavy Industrial machines, Test Rigs, Heavy presses, crushers etc.

DRC1-hs5-215-FG-GR	1780	M12X100	98	109	215	8	Dhs5	80	0.8	5	From -16 to 90
DRC2-hs5-215-FG-GR	3440	M16X100	125	150	215	8	Dhs5	80	0.8	5	From -16 to 90
DRC3-hs5-215-FG-GR	4950	M16X100	150	170	215	10	Dhs5	80	0.8	5	From -16 to 90
DRC4-hs5-215-FG-GR	6350	M18X150	180	210	215	10	Dhs5	80	0.8	5	From -16 to 90
DRC5-hs5-215-FG-GR	10640	M20X150	204	240	215	12	Dhs5	80	0.8	5	From -16 to 90
DRC6-hs5-215-FG-GR	13740	M20X150	235	270	215	12	Dhs5	80	0.8	5	From -16 to 90

Applications : Forging Hammers, Heavy Gen Sets, Heavy Industrial machines, Test Rigs, Heavy presses etc.

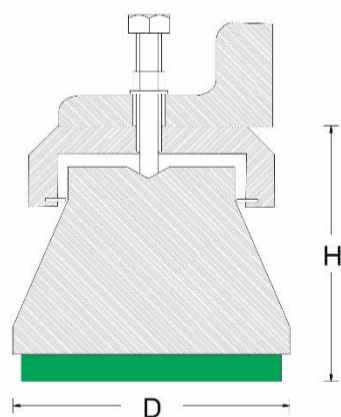

DRC2



DRC4



DRC6

DRC1-h-150-FG-GR	1200	M12X100	98	109	150	8	Dh	15	0.6	45	From -16 to 90
DRC2-h-150-FG-GR	2400	M16X100	125	150	150	8	Dh	15	0.6	45	From -16 to 90
DRC3-h-150-FG-GR	3500	M16X100	150	170	150	10	Dh	15	0.6	45	From -16 to 90
DRC4-h-150-FG-GR	5200	M18X150	180	210	150	10	Dh	15	0.6	45	From -16 to 90
DRC5-h-150-FG-GR	7200	M20X150	204	240	150	12	Dh	15	0.6	45	From -16 to 90
DRC6-h-150-FG-GR	9600	M20X150	235	270	150	12	Dh	15	0.6	45	From -16 to 90

Applications : Very Heavy and long bed machines, long machining centres, planners etc.

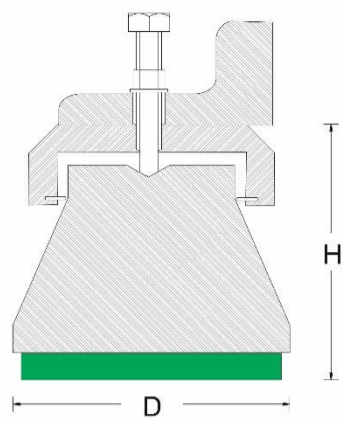

DRC2



DRC4



DRC6

DRC1-a2-143-FG-GR	640	M12X100	98	109	143	8	Da2	8	0.9	35	From -16 to 90
DRC2-a2-143-FG-GR	1230	M16X100	125	150	143	8	Da2	8	0.9	35	From -16 to 90
DRC3-a2-143-FG-GR	1770	M16X100	150	170	143	10	Da2	8	0.9	35	From -16 to 90
DRC4-a2-143-FG-GR	2270	M18X150	180	210	143	10	Da2	8	0.9	35	From -16 to 90
DRC5-a2-143-FG-GR	3800	M20X150	204	240	143	12	Da2	8	0.9	35	From -16 to 90
DRC6-a2-143-FG-GR	4900	M20X150	235	270	143	12	Da2	8	0.9	35	From -16 to 90